

UNLESS OTHERWISE SPECIFIED:

DIMENSIONS ARE IN INCHES
 TOLERANCES:
 FRACTIONAL \pm
 TWO PLACE DECIMAL \pm
 THREE PLACE DECIMAL \pm

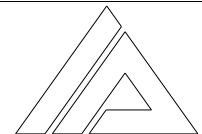

INNOVATIVE ARMS

SIZE	PART#	REV
	1/2-28 RH	

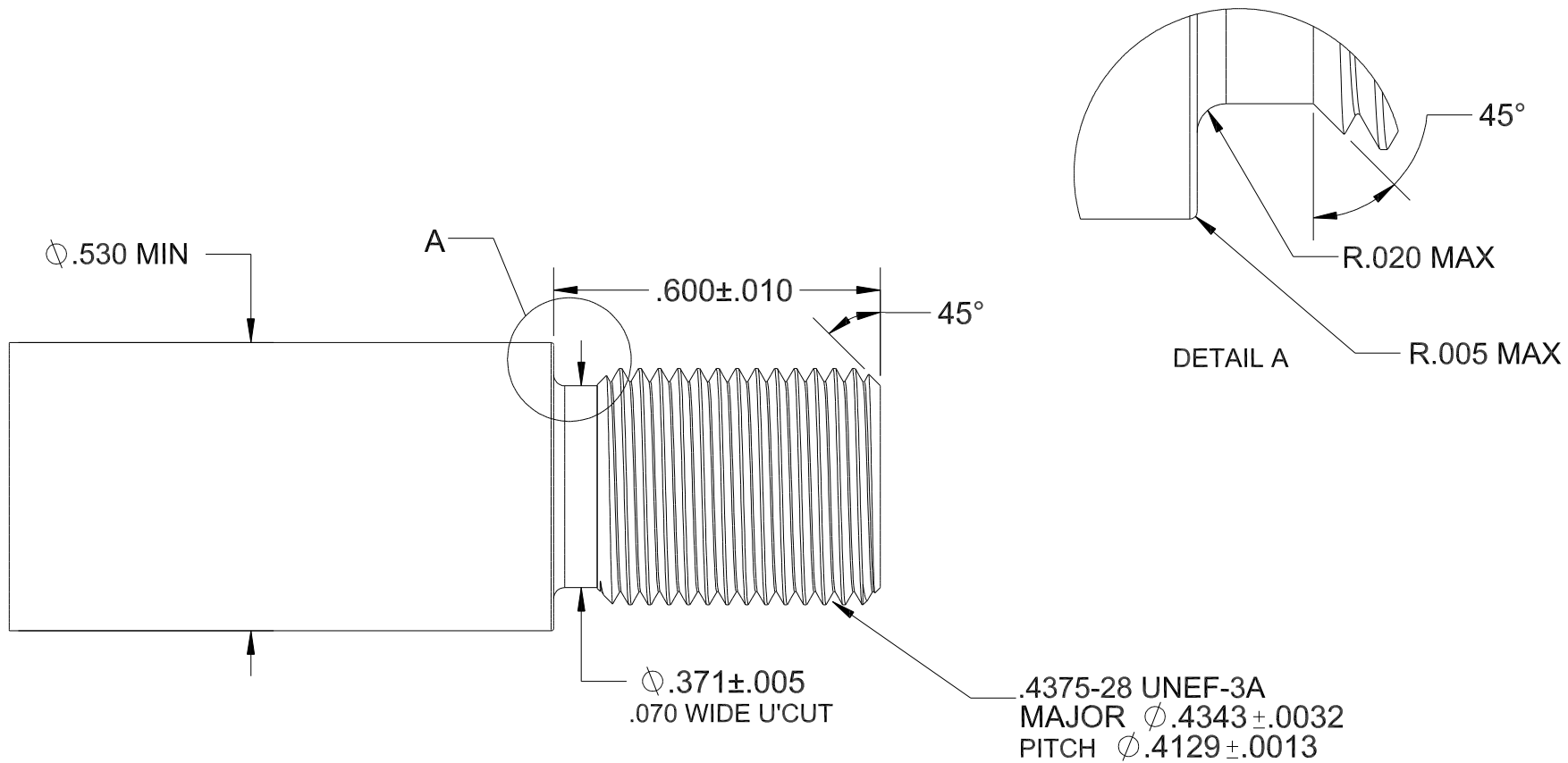

UNLESS OTHERWISE SPECIFIED:

DIMENSIONS ARE IN INCHES
 TOLERANCES:
 FRACTIONAL \pm
 TWO PLACE DECIMAL \pm
 THREE PLACE DECIMAL \pm

 INNOVATIVE ARMS		
SIZE	PART#	REV
	7/16-28 RH	

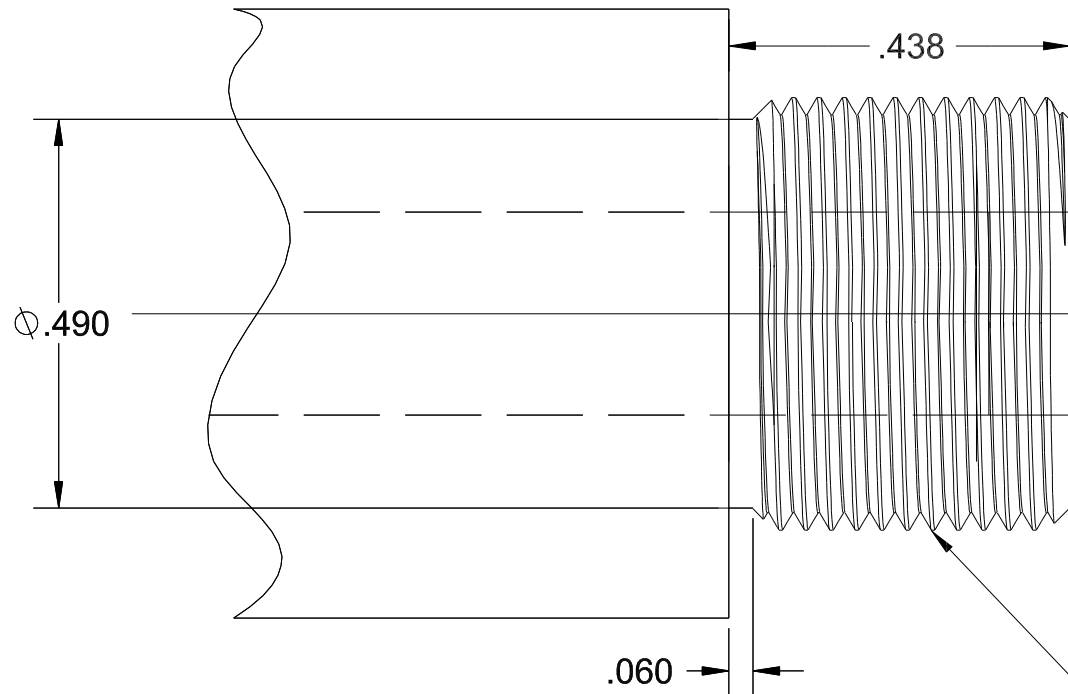

.5625 - 24 TPI
 MAJOR ϕ .5595 \pm .0030
 PITCH ϕ .5344 \pm .0010

$\text{\textcircled{C}}$ ϕ .003 | A

UNLESS OTHERWISE SPECIFIED:

DIMENSIONS ARE IN INCHES
 TOLERANCES:
 FRACTIONAL \pm
 TWO PLACE DECIMAL \pm
 THREE PLACE DECIMAL \pm

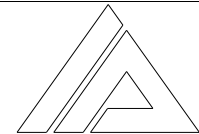

INNOVATIVE ARMS

SIZE	PART#	REV
	9/16- 24 RH "PISTOL"	

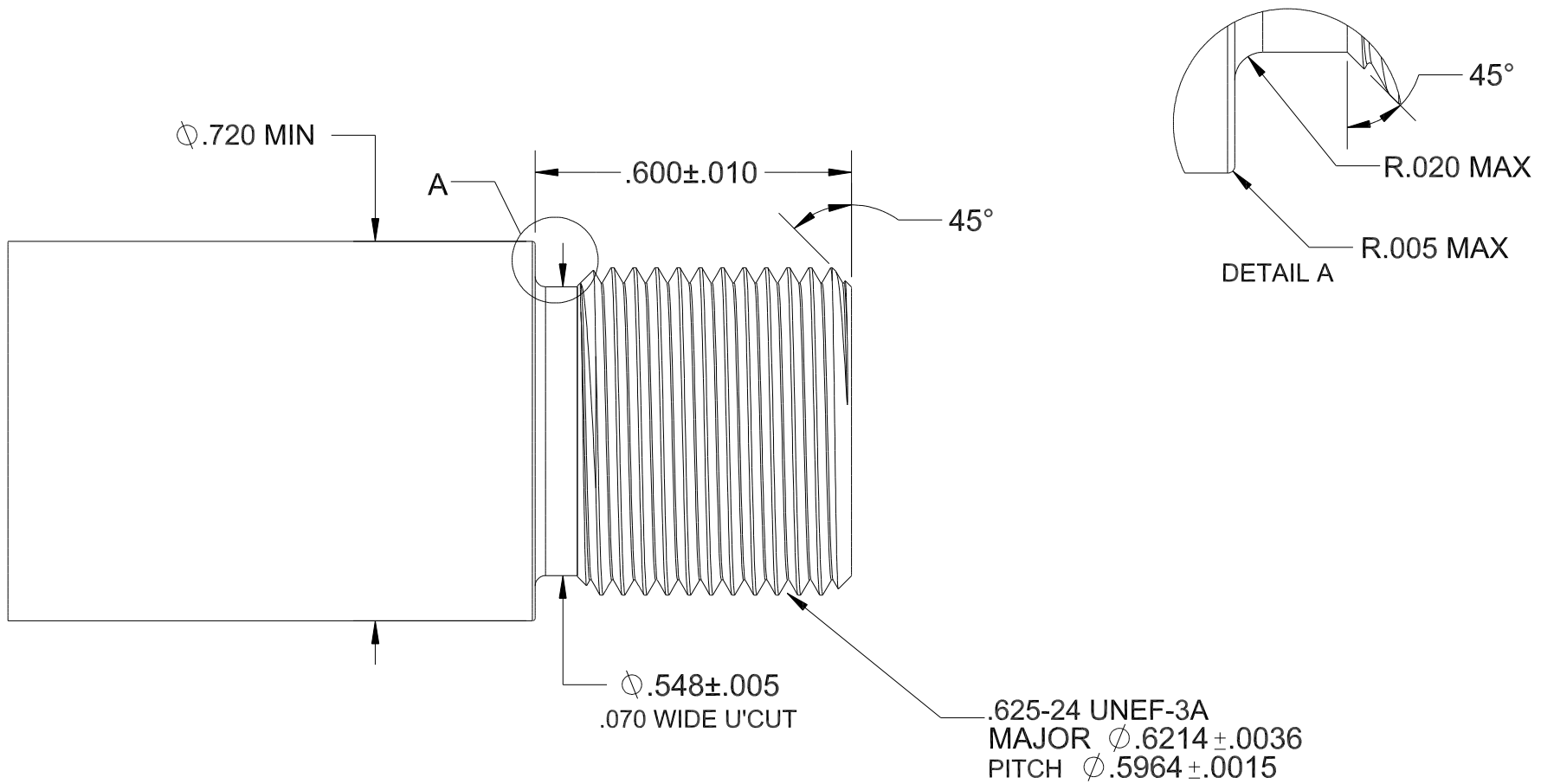

UNLESS OTHERWISE SPECIFIED:

DIMENSIONS ARE IN INCHES
 TOLERANCES:
 FRACTIONAL ±
 TWO PLACE DECIMAL ±
 THREE PLACE DECIMAL ±

 INNOVATIVE ARMS		
SIZE	PART#	REV
	5/8-24 RH	

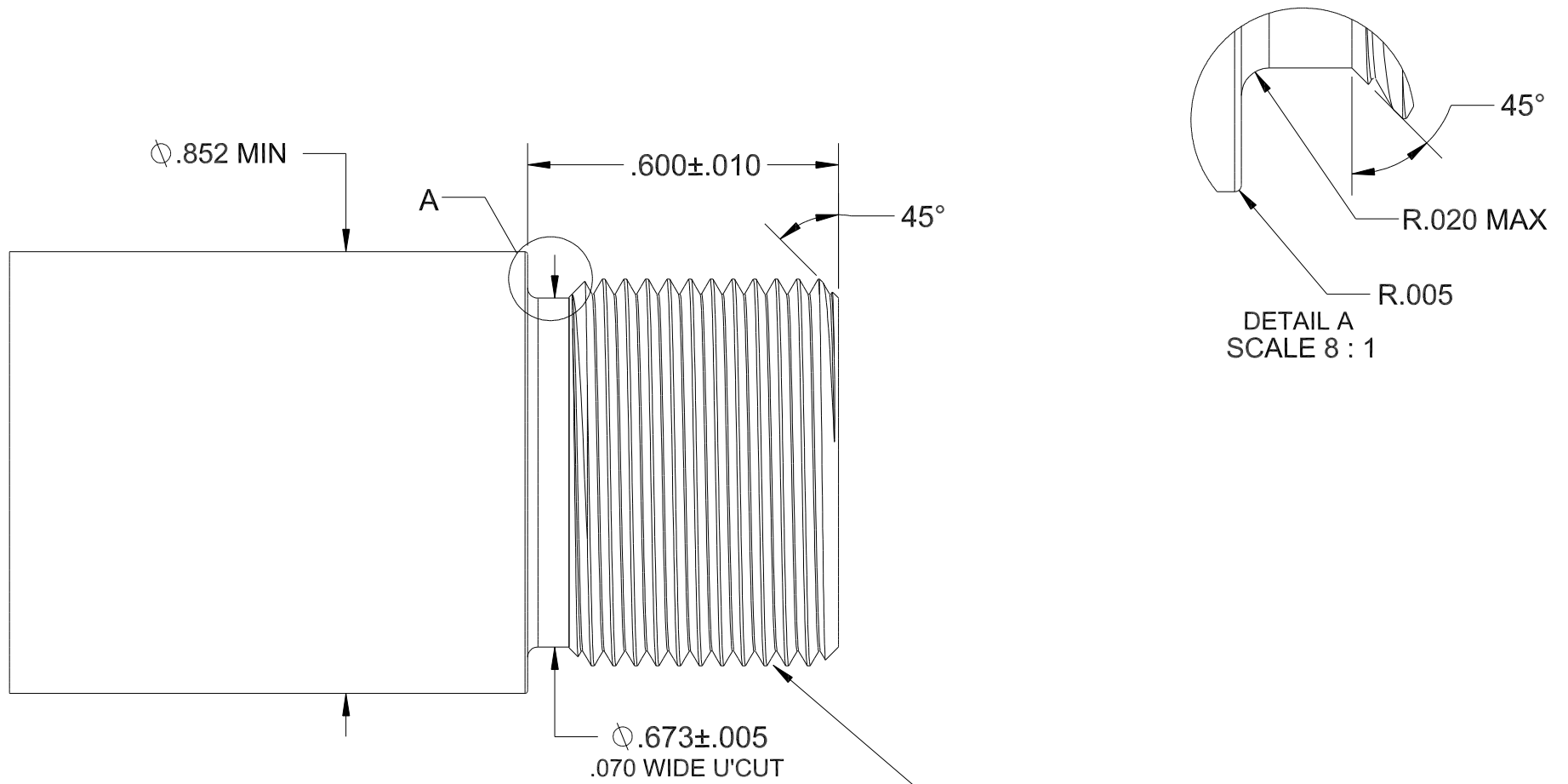

.750-24 UNS-3A
 MAJOR $\phi .7464 \pm .0036$
 MINOR $\phi .7213 \pm .0015$

UNLESS OTHERWISE SPECIFIED:

DIMENSIONS ARE IN INCHES
 TOLERANCES:
 FRACTIONAL \pm
 TWO PLACE DECIMAL \pm
 THREE PLACE DECIMAL \pm

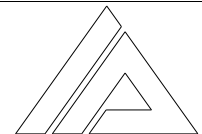

INNOVATIVE ARMS

SIZE	PART#	REV
	3/4-24 RH	

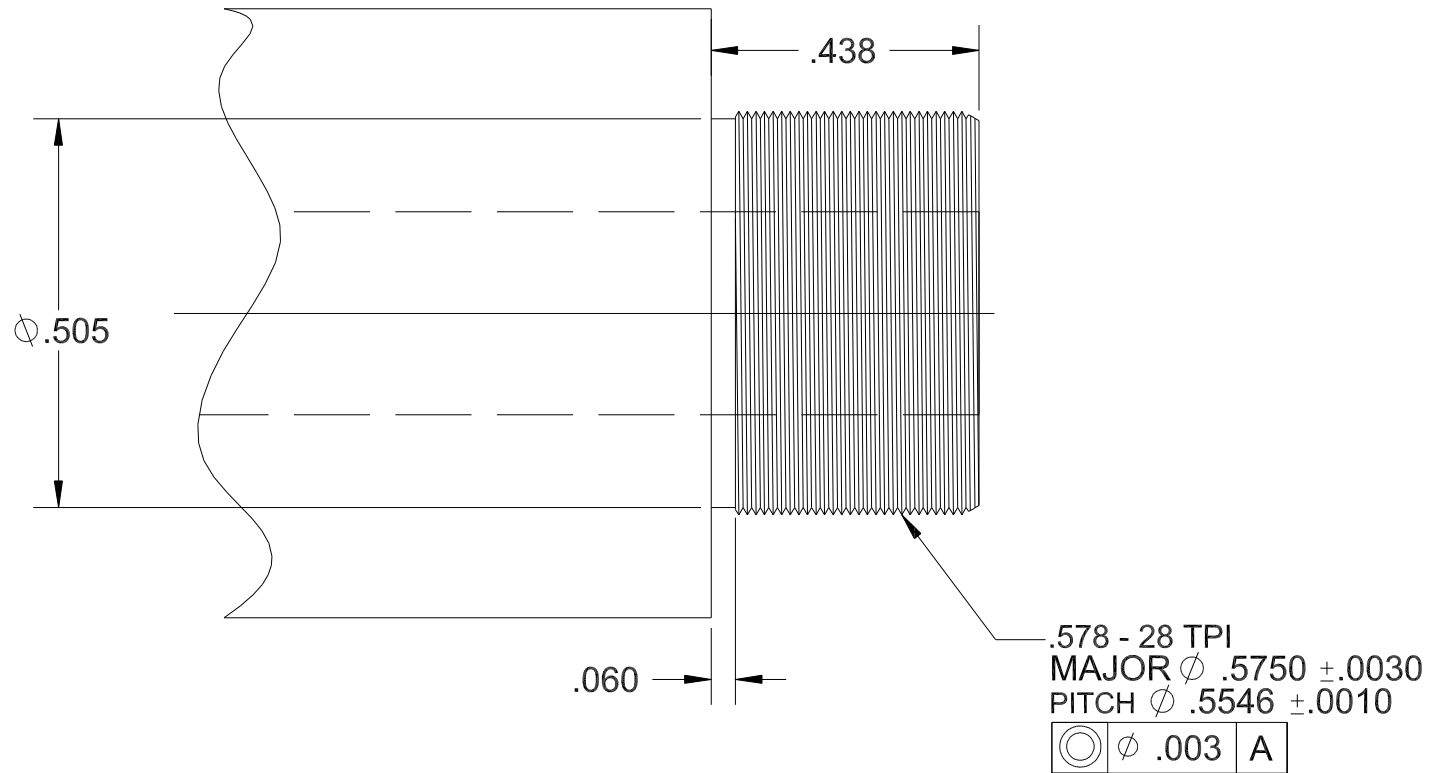

UNLESS OTHERWISE SPECIFIED:

DIMENSIONS ARE IN INCHES
 TOLERANCES:
 FRACTIONAL \pm
 TWO PLACE DECIMAL \pm
 THREE PLACE DECIMAL \pm

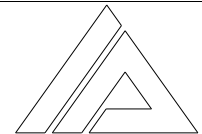

INNOVATIVE ARMS

SIZE	PART#	REV
	.578 - 28 RH	

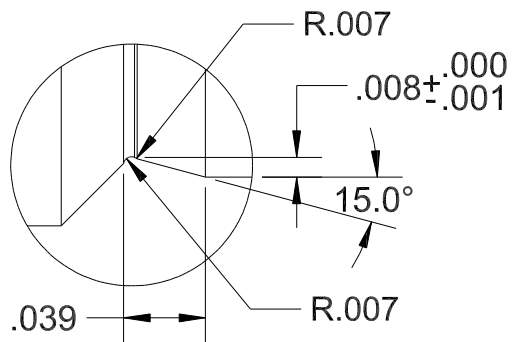
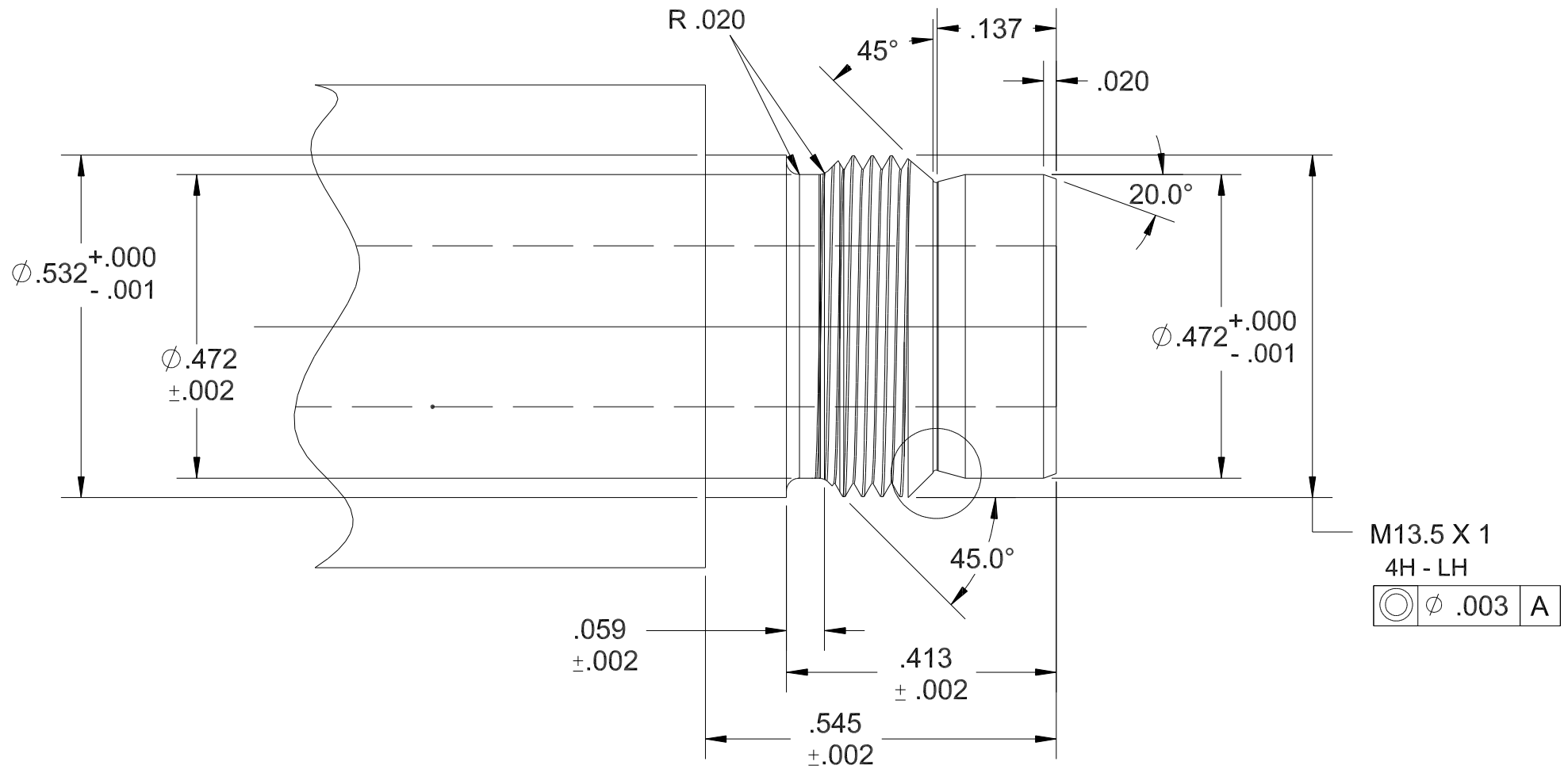

UNLESS OTHERWISE SPECIFIED:

DIMENSIONS ARE IN INCHES
 TOLERANCES:
 FRACTIONAL \pm
 TWO PLACE DECIMAL \pm
 THREE PLACE DECIMAL \pm

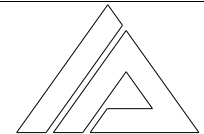

INNOVATIVE ARMS

SIZE	PART#	REV
	M13.5 X 1 LH	

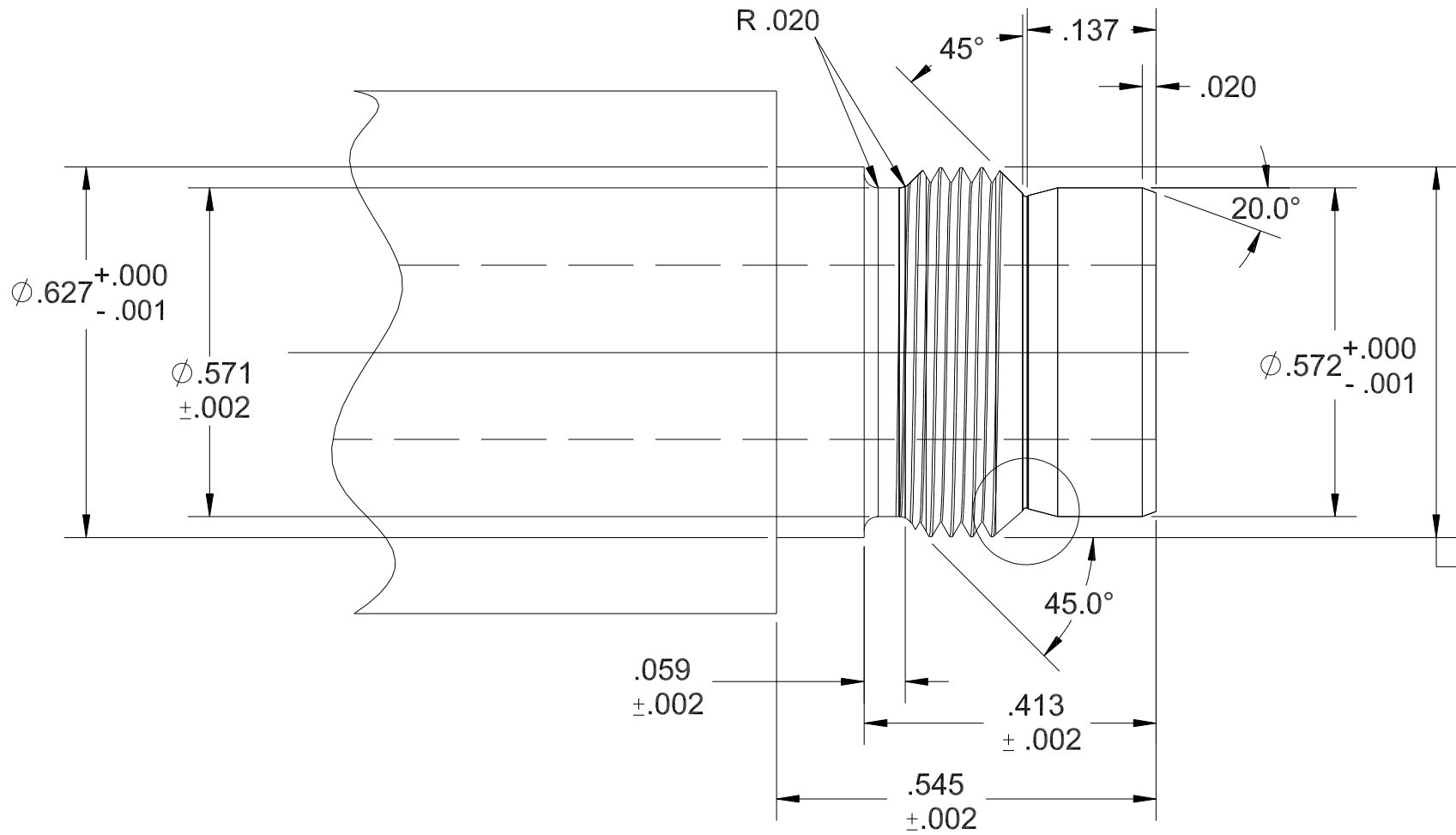

M16 X 1
 4H - LH
 $\phi .003$ A

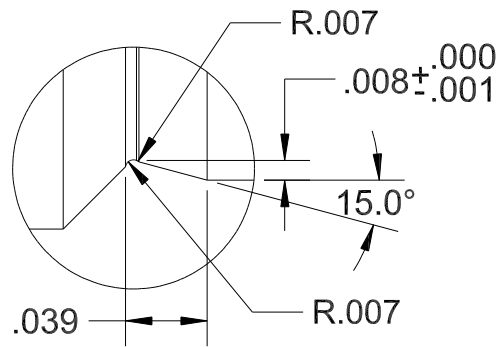

UNLESS OTHERWISE SPECIFIED:

DIMENSIONS ARE IN INCHES
 TOLERANCES:
 FRACTIONAL \pm
 TWO PLACE DECIMAL \pm
 THREE PLACE DECIMAL \pm

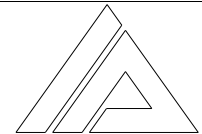

INNOVATIVE ARMS

SIZE	PART#	REV
	M16 X 1 LH	

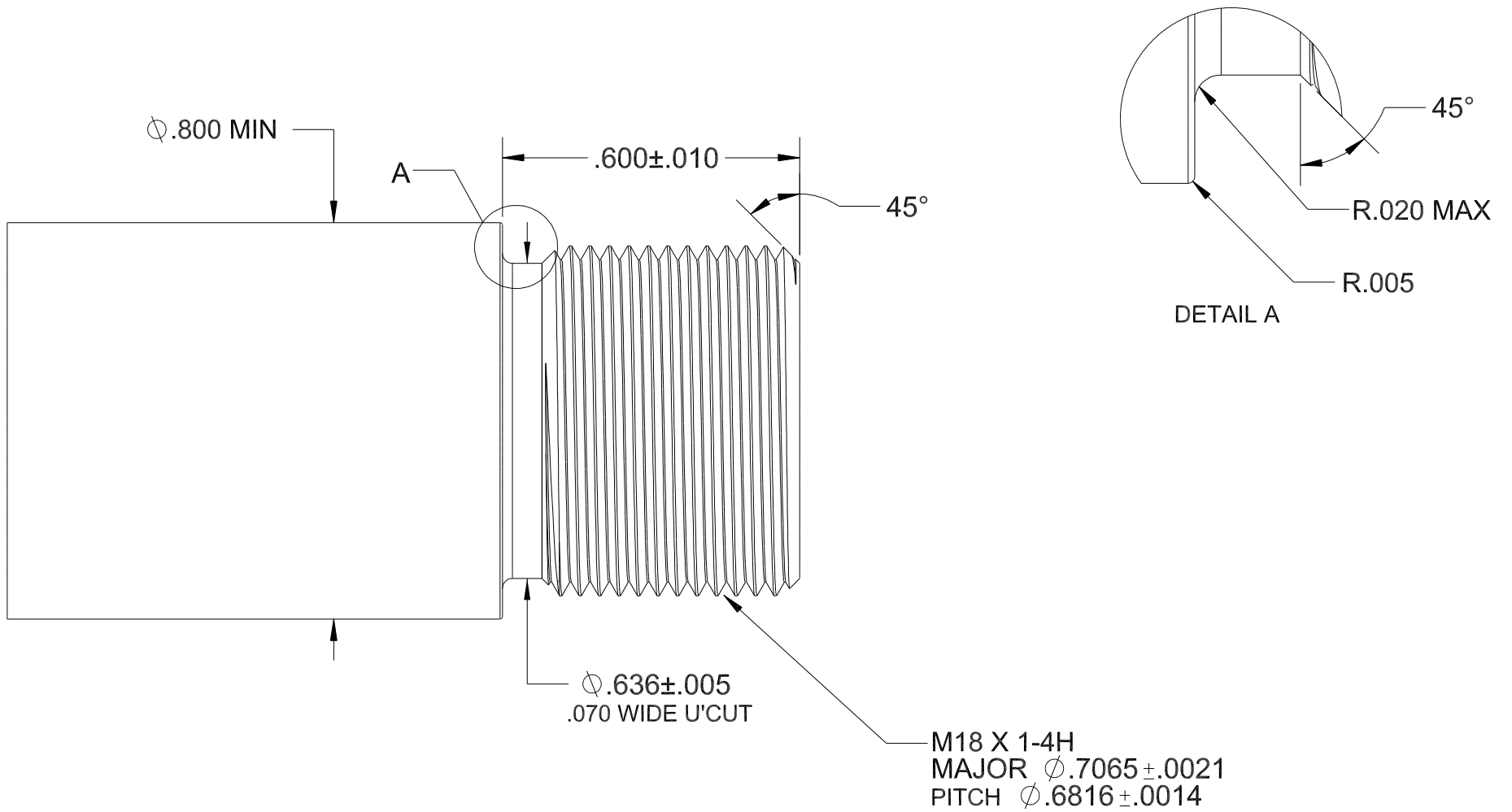

UNLESS OTHERWISE SPECIFIED:

DIMENSIONS ARE IN INCHES
 TOLERANCES:
 FRACTIONAL \pm
 TWO PLACE DECIMAL \pm
 THREE PLACE DECIMAL \pm

 INNOVATIVE ARMS		
SIZE	PART#	REV
	M18 X 1 RH	